

### The Schell Memorial Bridge.—I.

This is a highway bridge crossing the Connecticut River at Northfield, Mass. About a half mile below, in this river, was an old covered timber bridge, carrying a track of the Central Vermont R. R. on its upper deck and a town highway below. This bridge had become unsafe from age and increase in the railroad traffic, and the new bridge was originally projected simply to take the place of the highway portion of the old bridge and to shorten the distance between the Northfield Seminary and the Moody Auditorium, where large numbers of people assemble at the summer conferences, and the station of the Boston & Maine R. R. and Central Vermont Ry., at South Vernon Junction.

The bridge was first designed for utilitarian purposes only, with three simple and independent spans, but the project for a new structure having been made known to Mr. Robert Francis Schell, of New York and Northfield, he offered to bear the expense of the new bridge, the abutments of which were to bear bronze tablets in memory of his father and mother. It was then decided to alter the design in order to make it more appropriate for its purpose as a memorial bridge, and with this object in view, the relative lengths of spans and the general outline of the bridge in elevation were modified, the three spans were covered by continuous trusses with curved upper and lower chords, and more elaborate and expensive portals, railings and abutments were built. Owing to the original conditions and the fact that certain details of alterations were not decided

of glacial formation, consisting principally of boulder clay, with a few strata of moist, sandy clay. It rises quite abruptly from low water to a level well above the east abutment, so that it was necessary to make quite a detour in the approach to avoid an excessive grade.

The west bank, of alluvial formation, consists of a stratified silt, with occasional pockets or thin strata of fine sand, underlaid by coarser sand and fine and coarse gravel.

The two masonry piers are located just above low water level, giving a river span of 352 ft. on pier centers. The shore span on the east side was limited to 80 ft. by the steepness of the bank, and the west shore span was made the same for symmetry.

The piers, from a level 4 ft. above low water, are of quarry-faced granite ashlar, with pointed-face ice breakers, and with tops pointed and

in 1:2 Portland cement mortar, and backed or filled with rubble concrete made by embedding field stones in rather wet concrete.

The foundation of the east pier is upon the boulder clay at a depth of 3 ft. below mean low water, and is 13x40 ft. at base and 10x37 ft. on top, built in four courses, the two lower of 18-in. rise and the two upper of 24-in. rise. This foundation was built in a cofferdam made from the excavated material, with some sand bags, the river being not much above its mean low water level when the foundation was laid. The foundation of the west pier is of nearly the same horizontal dimensions as the east pier, but is one 18-in. course less in height, and rests upon 56 oak piles in staggered rows 2½ ft., center to center. The piles average 7 in. diameter at top, 10½ in. diameter at the level where cut off, 1 ft. below mean low water, and

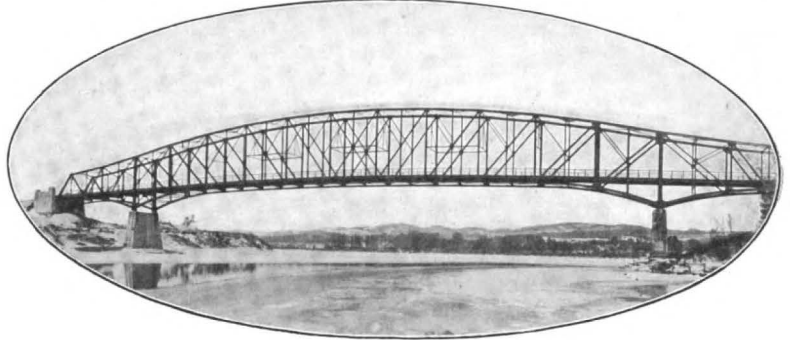

The Schell Memorial Bridge across the Connecticut River.

upon until after contracts had been let and work was well under way, the results are not so satisfactory to the designer as they might have been with a more complete knowledge of the purpose and ultimate cost at the outset.

At the location selected for the site of this bridge as being most satisfactory for the approaches, the river is much narrower than at any other available crossing, but just above the bridge the stream widens and trends to the west at a large angle, making the current irregular and oblique to the banks, which are here curved and irregular.

The maximum depth of water is about 25 ft. (at mean low water), with an ordinary or not infrequent spring flood rise of 28 ft., and an estimated maximum rise of 33 ft.

The easterly bank of the river is evidently

bridge seat bearings bush-hammered to level.

The granite facing of the piers was cut at the Lebanon (N. H.) quarries from course plans giving the exact dimensions of each stone, with joints, which were specified to be cut to lay from ⅜ in. to ¾ in. for 8 in. back from the face on bed and build. The courses have a uniform rise of 2 ft. and a thickness varying from 20 in. for the upper courses, to 24 in. for the lower courses. The principal pier dimensions are: 26x6 ft. at the top, 36x9 ft. at the base, and 28 ft. high above top of foundation, or 32 ft. above mean low water.

The granite facing is bonded generally with one header to every two stretchers, and is provided with a base or plinth course projecting 3 in., and a flush coping, the upper corners of plinth and coping being rounded. The face stones are laid

22 to 29½ ft. in net length, the shorter piles being generally in the inner rows.

The cofferdam for the west pier consisted of a double row of 3-in. spruce sheet piling on river side and ends of pier, and a single row of the same on the bank side, with earth filling. The sheet piling was driven after the main piles and the enclosure was pumped dry previous to cutting off the butts of the piles and laying the concrete. In this foundation 6 in. of dry broken stone was spread over the sand bottom to dry it before laying the concrete. The 1:2:4 concrete in both foundations was mixed with Alsens imported Portland cement, good clean and coarse, sharp sand found at and near the site of the west pier, and with broken stone, averaging 2 in., and not exceeding 2½ in. The suction hose of the pumps terminated in wells formed by lengths of 18-in. sewer pipe, which were eventually filled with concrete.

The abutments are of concrete, faced above the grade lines with small ashlar (granite from the same quarries as that for the piers) and reinforced with steel I-beams. The abutments are wider than the superstructure of the bridge, and their side walls, which are parallel with the line of the bridge, are carried up about 4 ft. above the surface of the roadway, forming parapet walls, coped with cut granite. These parapets are terminated at both ends by substantial stone posts wider than the parapets, rising above them, and covered with caps of cut stone. Two of the larger stone posts are placed at the ends of the bridge seats and outside of the bearings, concealing the bearings from a side or approach view.

The west abutment, here illustrated, is in the form of a rectangular box, open on top and bottom, and supported at its four corners upon concrete piers, which extend down nearly to low-water level and rest upon oak piles. Steel I-beams 8 in. deep are embedded in the concrete about 3 ft. above the tops of the piers which support the abutments, on all four sides,

these beams being in pairs, spaced, by clamp irons, far enough apart to fill and ram concrete between them, and additional I-beams and iron bars were built into the concrete higher up, as shown.

The east abutment is founded upon the Boulder clay, with the foundations of its side walls stepped up parallel with the grade. The face, or bridge seat, of this abutment is not recessed below the bearing line of superstructure.

Both abutments are provided with pairs of anchor rods at each bearing of trusses, two wrought-iron bars 2 in. diameter, upset, with double nuts on upper end, and with single nut and steel bearing-plate on lower end, these plates bearing up against two short I-beams, which are placed under long I-beams extending across the abutments transversely, two in the west abutment and three in the east abutment.

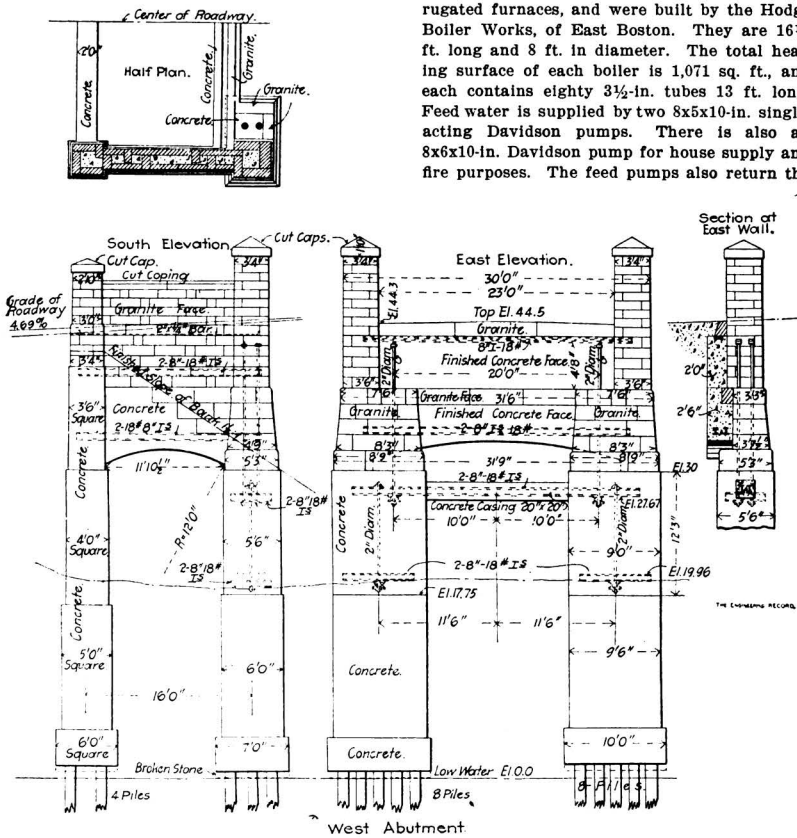

**The Power Plant of the Oliver Building, Boston.**

By Howard S. Knowlton.

An interesting isolated plant has recently been completed in the new 11-story Oliver Building in Boston. In general design the structure resembles the Board of Trade Building in Boston, owned by the same interests. The general contractors were the Thompson-Starrett Co., of New York and Boston, and the architect was Goldwin Starrett, of New York. Messrs. Winslow and Bigelow, of Boston, were retained as consulting and supervising architects.

The power plant is located centrally in the basement, and it supplies all the heat, light and power used in the building. The four 150-h.-p. boilers are set up in a room adjoining a pump room and an engine room. They are of the Scotch marine type with Morison internal corrugated furnaces, and were built by the Hodge Boiler Works, of East Boston. They are 16 1/4 ft. long and 8 ft. in diameter. The total heating surface of each boiler is 1,071 sq. ft., and each contains eighty 3 1/2-in. tubes 13 ft. long. Feed water is supplied by two 8x5x10-in. single-acting Davidson pumps. There is also an 8x6x10-in. Davidson pump for house supply and fire purposes. The feed pumps also return the

of this system. The plant includes a blow-off tank 3 ft. 6 in. in diameter by 6 ft. long; a hot water tank 3 ft. in diameter and 6 ft. long; a 1,500 gal. suction tank, and a 3,000-gal. house tank.

The building is served by five 5 1/2 x 6 1/2-ft. passenger elevators, made by the Plunger Elevator Co., of Worcester, Mass. Each elevator has a 6 1/2-in. steel plunger. Three of the elevators have an average lifting capacity of 1,500 lb. at a speed of 400 ft. per minute, and a maximum lifting capacity of 2,500 lb. at a somewhat slower rate. Two elevators run from the basement to the eleventh floor, a distance of 124 ft. The other three run from the street floor to the eleventh, a rise of 112 ft. One of these elevators is direct-connected to a jack pump, and with this pump carries a load of 8,000 lb. at slow speed.

The valve gear of three of the Davidson elevator pumps is arranged to give a uniform performance on both sides of a duplex cylinder combination; these pumps are 14 and 26x12x24-in. compounds. There are also two simple Davidson elevator pumps, one 16x9 1/4 x 16 in. and the other 16x14x12-in.

There are two pressure tanks for the elevator system, each 84 in. in diameter and 13 ft. long, installed in the engine room, and also a 15x7 1/2 x 8 1/2-ft. discharge tank. Armstrong flash signals are provided for the cars.

The engine room at present contains two 75 k.w. General Electric 115-volt generators, one 50 k.w. machine, and a 25 k.w. unit for light loads. The 75 k.w. machines are direct-connected to two simple 14x14-in. 120-h.-p. non-condensing automatic engines, built by the Harrisburg Foundry & Machine Works. The 50-k.w. generator is connected directly to an 80 h.-p. 12x12-in. Harrisburg engine. The 25 k.w. dynamo is driven by a 40-h.-p. 9x10-in. Harrisburg engine, to which it is direct-connected.

The piping system possesses various features of interest. Branch boiler headers are connected to a 10-in. main header, and connections taken from this lead to the feed pumps, electric light engines, elevator pumps and a reducing valve on the heating system. The auxiliary main first taken off supplies steam to the small pumps, hot water generator and the injectors. All the high pressure piping is dripped through Kieley steam traps, each provided with a three-valve by-pass.

The exhaust from all the pumps, engines and air compressors is connected to a main running under the floor to the feed water heater. The main then rises to the engine room ceiling, where it has a Cochrane grease extractor. After the exhaust main leaves the grease extractor a tee is provided for connection with the heating system, and the main then rises to the roof. It has a Kieley back pressure valve. A vapor pipe runs from the boiler blow-off tank alongside the exhaust pipe to the roof to drain the exhaust head. A system of drain pipes connects all the pumps in the building with the sump pit. The hot water tank is controlled by a Davis & Roesch regulator and a Davis & Roesch valve on the main steam supply.

The boilers and steam heating system of the building were installed by the Cleghorn Company of Boston. The building can be heated either by exhaust or live steam through a reducing valve. Steam is taken from the main exhaust piping just inside the back pressure valve. From this point the main steam riser goes to the roof to horizontal mains, from which risers extend down through the building to the second floor. Each riser throughout the building is anchored to the steel work at one-quarter the height from the top and one-quarter the height from the bottom, and provided in the center with an expansion joint.

In the west abutment the anchor rods are extended in separate and single lengths about 10 ft. farther down into its supporting piers, and terminate on bearing plates and pairs of steel beams placed in two directions, as shown. All steel beams in abutments are 8 in. 18-lb. I-beams.

The anchor rods were enclosed in wells formed by placing lengths of 6-in. stove pipe in the concrete as it was laid up. After the superstructure was erected these wells were filled with cement grout.

The surfaces of bridge seats, back of the narrow granite facing, and the face of the recess above the bridge seat, have a concrete finish, with granite coping just below roadway surface.

(To be continued.)

water of condensation from the heating system to the boilers. The pump room also contains two Monitor injectors for boiler feeding, and a brick-lined sump, 3 ft. by 5 ft. in area and 3 ft. deep, lined with brick.

Coal is brought from the bins to the boilers by a 500-lb. car running on a narrow gauge track to a platform scale. After the fuel is weighed, the car is turned by a turntable arrangement and run in front of the furnaces, the boiler room track being at right angles to that leading from the bins to the scales.

The feed water is heated by a 600 h.-p. "American" heater, with by-passes on both the steam and water connections. The building is supplied with cold drinking water through a system installed by Steele & Condit, of Jersey City. Two Knowles pumps drive the apparatus

thus avoiding, so far as possible, the heating of refuse that may be stored in the hoppers previous to charging.

The settling chambers at either end of the section are 14x10 ft. Each set of cells, together with a settling chamber, an air heater, a fan and a boiler, form one unit of the plant.

The floor of the second story is constructed of steel joists and concrete, and is 14 ft. below the lower members of the roof trusses. This story contains, in addition to the tipping platform, an enclosed area in which the fans and their engines are located. The two 66-in. fans are direct-connected to enclosed 12-h.p. self-oiling Belliss engines, and have their suction openings in the second story in close proximity to the refuse hoppers. They were located in this manner to assist the circulation and removal of the foul air arising from the refuse in storage in the hoppers. The fans are placed directly over the heaters, to which they are connected by square steel tubes extending down from their exhausts.

The boiler house, 73 ft. 6 in. x 24 ft. 6 in. in plan and one story high, is next to the destructor house, the two having a common wall. A large flue from the air heater in the destructor house to the economizer and chimney, runs across the center of the building at a low level. Two boilers are placed on one side of this flue, and a third one and an economizer on the other side. Two of the boilers are connected to the furnaces of the destructors, and operate on the gases from them, while the other one will be adapted for coal firing, but will be held in reserve. The boilers are of the Lancashire type, furnished by Taylor & Sons, Marsden, Yorkshire. They are 30 ft. long and 8 ft. in diameter, designed to be operated at a pressure of 160 lb. per square inch. The economizer has 128 tubes, each 9 ft. long, and 4 9/16 in. diameter, with a total of about 1,500 sq. ft. of heating surface.

The flues within the boiler house are of large dimensions, to secure easy access for cleaning. The main flue from the air heater through the boiler house to the economizer and thence to the chimney has a considerably increased cross-section in order to decrease the velocity through it and to facilitate the settlement of dust that has passed over from the furnaces. The brick chimney to which this flue leads is 165 ft. high, with an internal diameter at the top of 7 ft., and is placed on a separate concrete base outside the boiler house.

Between the boiler house and the generator building is a small wing connecting the two. The engine room is 36 ft. long, 28 ft. 6 in. wide, and 22 ft. high from the floor to the roof trusses. It contains two British Thomson-Houston standard 115-kw., 2,000-volt, 50-cycle, revolving-field, three-phase generators, direct-connected to Belliss engines. These engines are of the compound two-crank type, of 175 h.p. each. A small lighting set is also placed in the engine rooms. The feed-water heater, oil separator and other appurtenances are located in the basement.

The eight cells and two boilers are guaranteed to evaporate not less than 9,000 lb. of water when the furnaces are fed at the rate of 8,000 lb. of refuse per hour. The plant is said to be of sufficient capacity to enable 60 tons of ordinary house refuse to be burned in 24 hr. on one set of four cells, which is equivalent to 56 lb. per square foot of grate. The cost of the plant, and its equipment, the land on which it is located, and two small cottages, was about \$125,000. It was built jointly by the Corporation of Birmingham and the Birmingham, Tame and Rea Drainage Board, the Drainage Board utilizing the electric power in some of its work.

### The Schell Memorial Bridge.—II.

The main trusses are continuous from abutment to abutment, with all of the dead weight borne on the two piers, and without any weight or reaction at the abutments except when a live load is on the bridge. The shore arms are designed to act as cantilevers, extending in a reverse direction, from the piers toward the abutments, when the bridge is unloaded. This purpose is accomplished by means of adjustable bearings placed under the ends of the trusses on the abutments, each bearing being raised or lowered by drawing together or slackening off two cast-iron wedges held together and adjusted by screw bolts and nuts.

The upper ends of the anchor rods, already referred to, pass through the abutment bearings and ends of the trusses, on which they bear by means of cast-iron washers and spiral steel freight-car springs, through which the anchor rods pass. The bearings were adjusted so as to leave a play of 1/32 to 1/16 in. between the ends of the trusses and the bearings below, and also between the washers on top of the springs and the nuts on the anchor rods. Although the abutment ends of the bridge are thus left free to expand and contract under temperature changes, their upward and down-

ward motion is checked by the anchor rods and springs, together with the adjustable bearings, so that the deflection of the trusses under moving loads is reduced and the vibration kept down to about the usual amount in a bridge of simple span of the same length.



End Span from Near Pier.

ward motion is checked by the anchor rods and springs, together with the adjustable bearings, so that the deflection of the trusses under moving loads is reduced and the vibration kept down to about the usual amount in a bridge of simple span of the same length.

The bearings rest on cast-iron bearings having a total depth of about 2 ft., on both piers. The bearings on the east pier are fixed or bolted to it, and those on the west pier are provided with sets of five cast-iron rockers or segmental rollers, 12 in. deep, toothed into the top and bottom castings so as to move with them.

The outline of the upper chords of the main trusses is a polygonal curve, convex upwardly in the central span, and reversed over the piers so as to be concave upwardly in the side spans. The roadway is on a straight grade of 9 in. in 16 ft., or 4.69 per cent. for 144 ft. from each abutment, these grades being connected over the central portion of the bridge by a vertical curve tangent to the grades. The lower chords of the trusses are parallel to this vertical curve throughout its length, but at the ends of the central span and in the side spans they have a greater curvature, and in the latter portions the soffits, or under surfaces of the lower

same height above the lower chords, transverse struts, formed of four angles, latticed, connect the chords below the floorbeams. The lower lateral diagonals are all angles, crossing each panel in two directions, each diagonal consisting of two angles in the panels of the middle span toward the piers, and single angles in the central panels of the middle span and in the side spans.

chords, are formed in true curves throughout. The upper surfaces of these chords are polygonal or formed in straight lines between web intersections. The curves of the lower chords approximate closely to tangent segments of circular arcs and were laid out, on detail drawings and templates, by thin strips of metal or wood sprung between fixed points.

The middle span of 352 ft. is divided into twenty-two floor panels of 16 ft. each, and the side spans of 80 ft. are divided into five panels of 16 ft. The web system is of the "Baltimore" type throughout the whole of the middle span and in the two panels adjacent to the piers in the side spans, with vertical posts, diagonals covering two panels, and sub-panel hangers, struts and diagonals. In the three panels next to each abutment the web system is simple triangular. The trusses and laterals have riveted connections throughout, the rivets being generally of 3/4 in. diameter.

The main floorbeams, each consisting of a 26x5/16-in. web-plate and four 5x3x3/8-in. flange angles, are riveted to the vertical posts and hangers above the lower chords, the posts and hangers being provided with web-plates in extension of the webs of the floorbeams at the points of juncture. In three panels adjacent to each pier where the floorbeams are at the

same height above the lower chords, transverse struts, formed of four angles, latticed, connect the chords below the floorbeams. The lower lateral diagonals are all angles, crossing each panel in two directions, each diagonal consisting of two angles in the panels of the middle span toward the piers, and single angles in the central panels of the middle span and in the side spans.

The upper lateral bracing consists of vertical transverse braced frames at every pair of main posts in the middle span, transverse struts each consisting of four angles latticed, in the plane of the top chord at intermediate points and at all points in the side spans, arched portal bracing connecting the posts over the piers, arched portals in vertical planes at the first panel point from each abutment, and single diagonal angles in the plane of the upper chords, extending over two panels, except in the portion of the middle span toward the piers, where there are two angles in each diagonal. All of the principal truss and lateral connections are formed of gusset plates, wider than the chords.

The upper chord is of the ordinary section, consisting of two side plates 16 in. deep, a top plate 20 in. wide, and four 3x3-in. angles, double

same height above the lower chords, transverse struts, formed of four angles, latticed, connect the chords below the floorbeams. The lower lateral diagonals are all angles, crossing each panel in two directions, each diagonal consisting of two angles in the panels of the middle span toward the piers, and single angles in the central panels of the middle span and in the side spans.

The upper lateral bracing consists of vertical transverse braced frames at every pair of main posts in the middle span, transverse struts each consisting of four angles latticed, in the plane of the top chord at intermediate points and at all points in the side spans, arched portal bracing connecting the posts over the piers, arched portals in vertical planes at the first panel point from each abutment, and single diagonal angles in the plane of the upper chords, extending over two panels, except in the portion of the middle span toward the piers, where there are two angles in each diagonal. All of the principal truss and lateral connections are formed of gusset plates, wider than the chords.

The upper chord is of the ordinary section, consisting of two side plates 16 in. deep, a top plate 20 in. wide, and four 3x3-in. angles, double

same height above the lower chords, transverse struts, formed of four angles, latticed, connect the chords below the floorbeams. The lower lateral diagonals are all angles, crossing each panel in two directions, each diagonal consisting of two angles in the panels of the middle span toward the piers, and single angles in the central panels of the middle span and in the side spans.

The upper chord is of the ordinary section, consisting of two side plates 16 in. deep, a top plate 20 in. wide, and four 3x3-in. angles, double





portions of the upper chord, and in the curved portions of the lower chord (which were in compression during erection), the stress line is either at or below the center of gravity of chord section at the middle of a panel length. The layout lines of upper and lower laterals are intersected upon the center lines of the chords in plan.

The steel floorbeams carry eight lines of 5x12-in. longleaf hard pine stringers, spaced 2 1/2 ft. apart on centers, and butted on the top flanges of the floorbeams, on which they are gained to varying depths to give a crown to the roadway. The floor planking is a single course of 3-in. chestnut, spiked to each stringer with 5/8-in. steel spikes. The curbs or wheel guards, which also serve as bases for the railings, are 6x12-in. hard pine, secured to the outer stringers, through the floor planking, by means of 5/8-in. lag screws. The railings are formed of four lines of wrought-iron pipe passing through cast-iron posts of special design, spaced 5 ft. 4 in. on centers and secured to the broad wheel guards on which they rest by lag screws. Every third railing post is also fastened to the adjacent post of the truss by means of a 3/4-in. bolt in slotted connection.

The steel work was primed with a coat of boiled linseed oil in the shops, and in the field was painted with one coat of No. 31 special and one of No. 16 special paint manufactured by the National Paint Works of Williamsport, Pa.

The quality of steel specified was very nearly that of the present grade of "railway bridge steel" of the manufacturers' standard specifications.

The bridge was designed to carry, in addition to its own weight (determined by detail esti-

mate) the above loads the unit stresses in tension will not exceed those given by the formulae

$$s = 10,000 \frac{100 + 4p}{100 + 2p}$$

and

$$s = 8,333 \frac{100 + 3p}{100 + p}$$

for general truss members, and for floorbeams, hangers and counters.

in which  $s$  = stress in pounds per square inch and  $p$  = 100 (minimum stress ÷ maximum stress), or the percentage of minimum to maximum stress. For the chords of the middle span the dead load stress was taken as the mini-

pose. In determining the live load stresses, the live load was assumed to cover the middle span, without resting on the end spans, and also to cover both end spans without resting on the middle span, and in both cases without weight or reaction at the abutments, although, under the maximum live loads, there will doubtless be some positive or negative reaction at the abutments, yet it is believed that the stresses found by allowing for such reactions would be less than the maximum assumed.

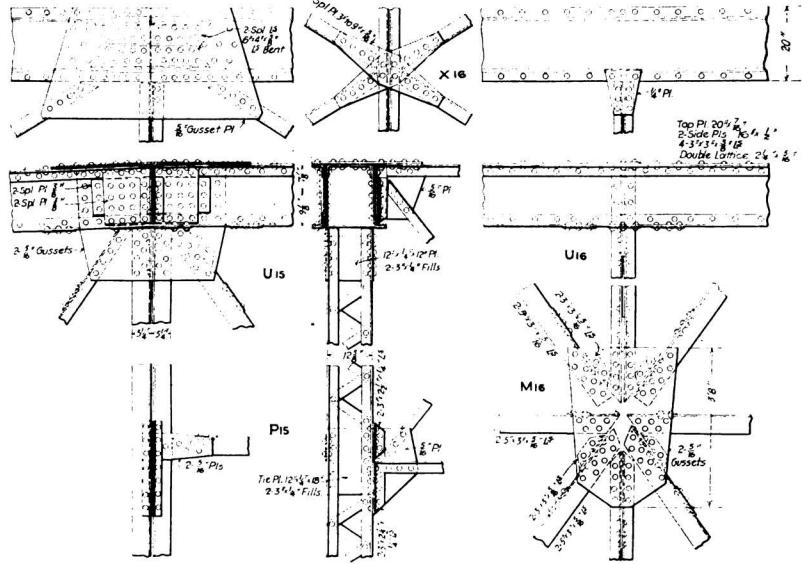

Connections at Main and Intermediate Panel Points of Middle Span.

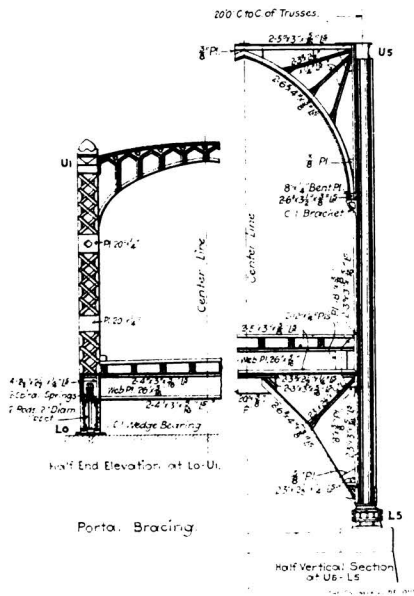

Details of Main Vertical Post, Portals and at Center of Channel Span.

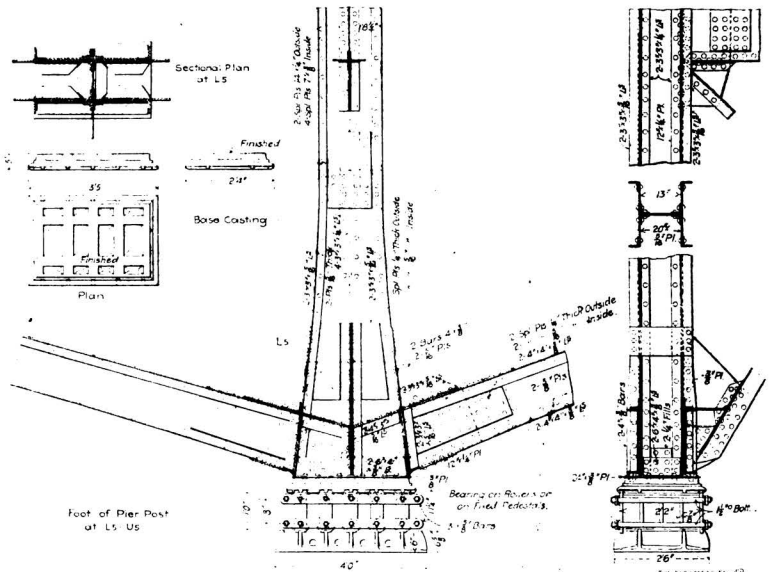

mates), a live load  $w = 60 + (2400 \div L)$  in which formula  $w$  = live load per square foot of floor surface and  $L$  = length of bridge covered by the load to produce the maximum stress in any member. This formula gives a load of 67 lb. per square foot for the condition of load covering the whole of the middle span, 90 lb. per square foot for load covering the side span, and for load covering 32 ft. of length, giving the maximum load on floor and sub-panel systems 135 lb. per square foot. With stresses produced

num stress. Compression members have stresses reduced from the above figures by a special formula. Lateral bracing was designed for a wind pressure of 338 lb. per linear foot of bridge on the lower chord and 225 lb. per linear foot on the upper chord, with unit tensile stresses of 18,000 lb. per square inch.

The bridge having been designed to be erected on the cantilever plan, the strength of the portions of the trusses in the shore spans and near the piers was made sufficient for this pur-

The estimated weight of steel in the superstructure, exclusive of railings, is 365 net tons. The cost of the bridge was \$42,000.

In the first installment of this description, printed last week, Mr. Schell's full name was incorrectly given, as it is Francis Robert Schell. (To be continued.)

THE NEW 5,000,000-GAL. REINFORCED CONCRETE RESERVOIR at East Orange, N. J., has been found to be watertight on testing.

The Schell Memorial Bridge.—III.

**Cantilever Erection by Cableway.**—Although when completed the Schell Memorial Bridge is a continuous bridge, with a central span of 352 ft. and two shore spans of 80 ft. each, it was treated for the purpose of erection as a cantilever bridge, with the shore arms of the cantilevers counterweighted by temporary earth loads, suspended in wooden cribs from the two panels adjacent to each abutment. All material for the bridge was delivered and stored on the west bank, and was put in place in the bridge by means of a wire rope cableway, supported on two wooden towers, the west tower being about 100 ft. high and the distance between towers

ing holes for rivets at connections were bored through main members and splice and gusset plates at the same time.

The deflection of the trusses during erection was computed independently in the engineering office of the contractor, and, graphically, by the designer, with results agreeing well with one another and with the actual results as found by levels taken during erection, due allowance being made for the omission of the weight of a 5-ton traveler at the outer end of each cantilever arm, the weight of which was included in the computed erection stresses and deflections, but which was not used in the actual erection. The ordinates of lower chord panel points were increased from those shown on the contract draw-

bridge was erected this distance was checked by the engineer for the contractor, by a measurement at the level of the bearings on tops of piers, made with a steel wire of No. 18 gauge, carried on small sheaves; one end was fixed and the wire hauled taut by means of a counterweight suspended from the other end. The length of span was marked on the wire by clips secured with set-screws, and the wire was tested on a measured base line with a known tension at the works of the contractor.

To compensate for the effects of the inaccuracy in distance, differences of temperature between fabrication in the shops and erection, and the stretch of the lower chords under dead and live loads, it was decided to set the cast-iron

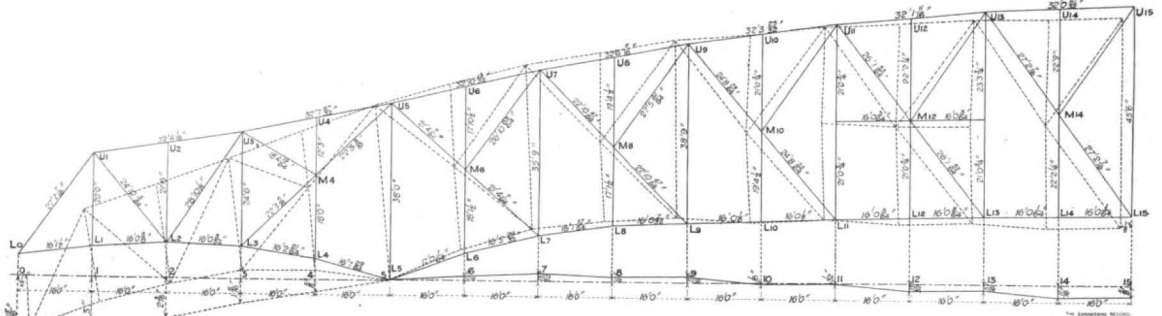

Dimensions and Deflections of Half the Bridge.

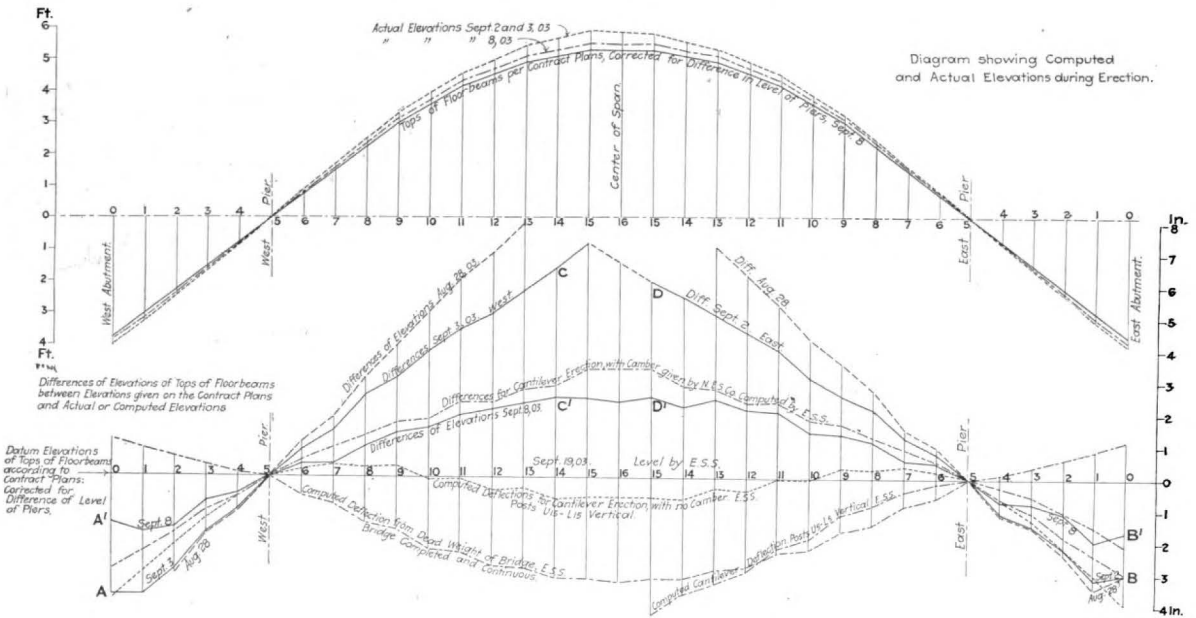

Diagram of Erection Elevations and Deflections.

200 ft. This method and the plant used involve a number of interesting features and details, of which there is no published description of previous use.

As the bridge was designed with riveted connections throughout, special care was taken in making the templets, in order that the several parts when brought together in the field without the support of falseworks might be connected with satisfactory results. The skeleton or center lines of members of one of the shore spans and one-half of the middle span were laid out with care on the floor of a large templet room, and all of the templets for a truss were assembled upon the lay-out lines and the mark-

ings, the increase at the center of the bridge being about the amount of the computed deflection at this point during erection. Erection stresses were computed not to exceed 16,000 lb. in tension and 14,500 lb. in compression, both per square inch of section, and allowing for the weights of travelers.

Upon the completion of the substructure the distance between the upstream bearings of the piers was ascertained by measuring across the river on the ice at the level of the bases of piers and plumbing up the centers of ice breakers with a transit, and was found to be about 1 in. less than the correct distance, at the assumed mean temperature of 40° Fahr. Before the

bearings of the trusses each 1½ in. inshore from the centers of bearings on piers. Moreover, in order to insure plenty of room for inserting the closing lengths of the trusses on a very hot day, the expansion bearings (segmental rollers) on the west pier were inclined at an angle toward the west bank and temporarily locked in that position.

The shore spans were erected as simple trusses upon single bents of falsework placed under the points L<sub>2</sub>, and additional shores under the points L<sub>4</sub>. The abutment ends at L<sub>0</sub> were set below their final level and held there by the earth counterweights until some of this earth was removed in order to lower the outer

ends of the cantilevers and make the center connections. The springs at the upper ends of the anchor rods were removed during the erection and sleeves of hardwood substituted.

The steel was picked up from its storage position on the west bank by the falls from the cableway. As the west cableway tower is about 100 ft. high, this did not require a very great

inclination of the falls, considering that any scattering pieces could be run in under the cable, by hand, upon timber rollers. Only one heavy member could be handled at one time by the cableway, and as it was necessary to shift the cable frequently from one side of the towers to the other (an operation which consumed a good deal of time in the early part of

the work, but which was later much expedited), the progress of the erection was not rapid, but was sufficient for the time capacity of the small gang of erectors employed and of the four gangs of riveters following, who were rather late in getting their start.

The cantilevers were erected one panel at a time from each side, the erecting gang shifting

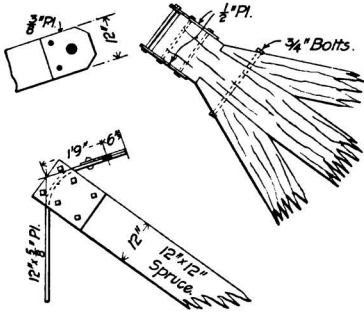
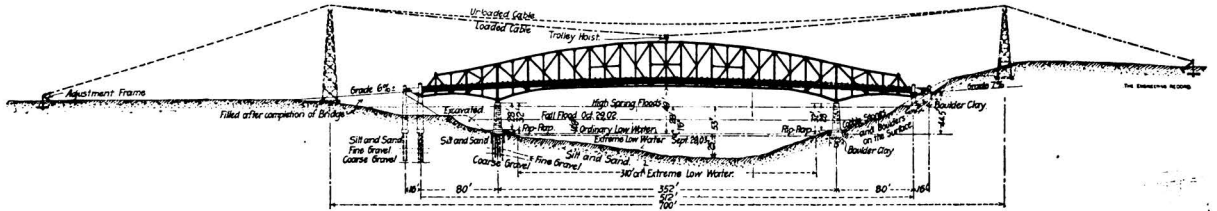

Knuckle Bearing at Top of West End Anchorage for Cableway.

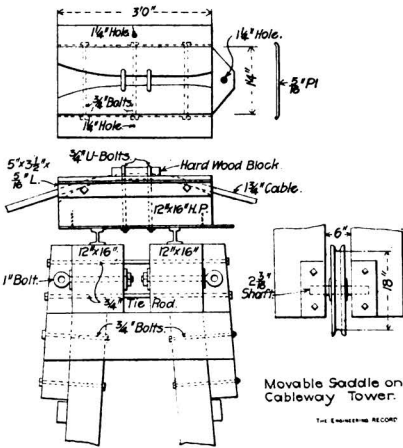

Movable Saddle on Cableway Tower.

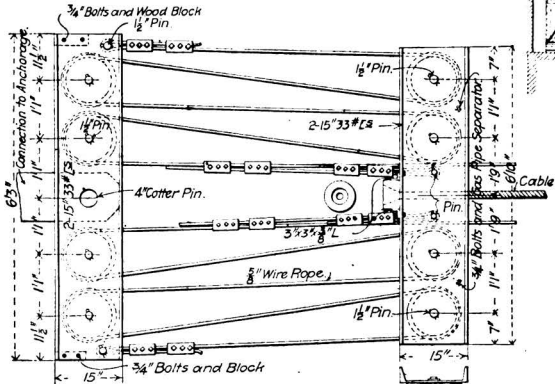

Adjustment Frame for Anchorage.

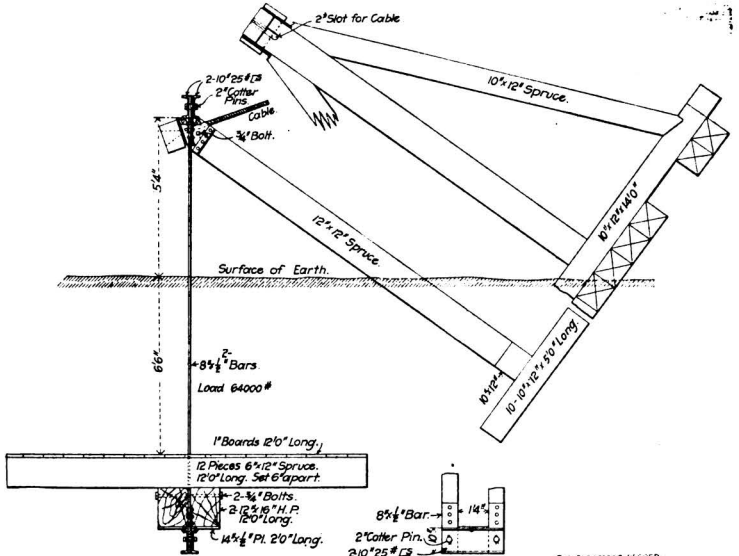

Anchorage for East End of Cableway.

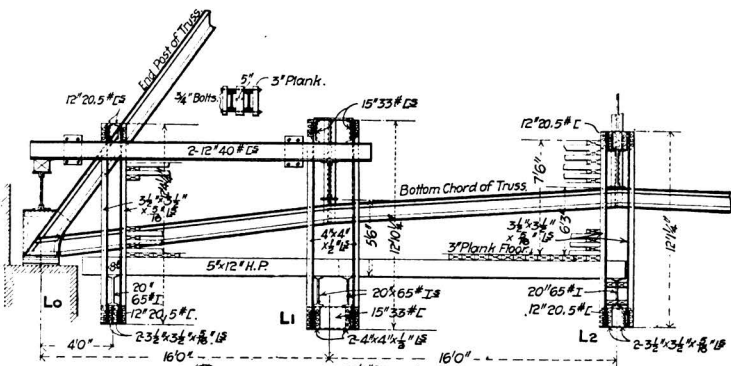

Suspended Platform for Temporary Counterweights for Erection Adjustment.

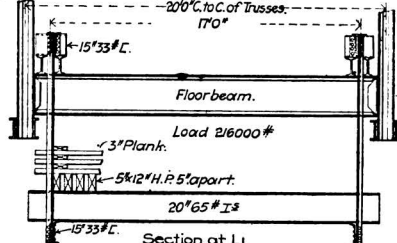

Section at LI.

from one side to the other to put in place the corresponding panels.

When all but the three middle panels had been erected the gap at the center was partly closed on the afternoon of Aug. 28, 1904, by swinging in three lengths of lower chord on the south side, and suspending two of these lengths by iron rope guys from the ends of the upper chord. Measurements and levels were then taken, with the result that there remained a gap in the lower chord at  $L_{12}$  of  $4\frac{1}{4}$  in., and that the top of the floor beam at  $L_{12}$  west was  $\frac{3}{4}$  in. higher than the corresponding floorbeam at  $L_{12}$  east.

Between this date and Sept. 3 the remaining parts of the trusses were erected and levels were taken, showing an elevation at  $L_{12}$  west  $\frac{1}{4}$  in. higher than at  $L_{12}$  east. On the afternoon of Sept. 3 the lower chords were drawn together, closing the gaps in these members, but leaving a gap in the upper chord of  $2\frac{1}{16}$  in. A part of the earth counterweight was then removed, bringing a slight stress on the anchor bolts, which were then slackened off so as to raise the shore ends and lower the outer ends of the cantilevers, thus closing the gap in the upper chord. Levels taken on Sept. 8, after the closure had been made (and when there was probably a slight compression in the upper chord and tension in the lower chord) show a fair correspondence in level of the two sides of the bridge.

A further deflection of  $2\frac{1}{4}$  in. at the center of the bridge was measured on Sept. 19, after the counterweights had been entirely removed and the flooring, except two panels of 16 ft. at each end, was in place. All of the above results are shown on the diagram. The counterweights consisted of sand and earth ballast in wooden bins supported upon steel beams suspended from the floorbeams at  $L_0$ ,  $L_1$  and  $L_2$  by temporary steel hangers, as shown by the detail, the total weight of each being about 108 net tons.

The cantilevers were erected (not including riveting) at a maximum speed of one double panel of 32 ft. in 18 hours, by a gang of six erectors, two men on shore to select and deliver material, and one man to operate the hoisting engine.

The riveting was done by four gangs of four men each, including heaters. Three of these gangs used air hammers, the fourth gang driving by hand hammers throughout. The compressed air for riveting hammers was carried across the river in a pipe suspended from the trusses, ineffectual attempts having been made to float this pipe.

The cableway was arranged in a special manner, and the towers, saddles and anchorages were designed and constructed by the contractors to provide for the special requirements of the work. The cable was a  $1\frac{1}{4}$ -in. crucible steel rope with a rated strength of 96 tons. It had a total length of 1,200 ft. and a clear span of 700 ft. The anchorages were about 1,160 ft. apart and were both fixed points, but the cable was supported on the tops of the towers on saddles having a transverse movement of 20 ft. The height of the cable was sufficient to give clearance for the hoisting tackle above the highest portion of the upper chord, and the transverse adjustment on the towers enabled it, when shifted, to command all portions of the superstructure. It was designed to have a maximum working stress, including that from its own weight, of 64,000 lb.

Each anchorage consisted of a timber platform buried about 7 ft. underground and connected with the end of the cable by vertical steel bars and a strut in the direction of the resultant of the stresses in the cable and the vertical anchor bars, the strut being composed

of three pieces of timber arranged in fan shape with the spread ends down and bearing on the earth through an inclined timber platform. At the east end the cable was coned into a cylindrical cast-iron block which bore upon a riveted steel angle block upon the upper end of the inclined strut. The vertical anchor bars were a pair of  $8\times\frac{1}{2}$ -in. bars with reinforced ends, pin-connected between the webs of pairs of short horizontal channels at top and bottom. The bottom channels supported the centers of a pair of  $12\times 16$ -in. horizontal timbers, 12 ft. long, which were bolted together and carried the anchorage platform, buried in the ground. The west cable was fitted with a clevis eye, which engaged a pin through the bent and reinforced end of a single  $12\times\frac{5}{8}$ -in. vertical suspension plate 14 ft. long, with top and bottom connections to the inclined strut and anchorage platform, as shown in the detail. The inclined strut was the same as at the east end, except that the cap differed as shown. The vertical anchor at the west end was connected to the short channels below the anchorage platform by a single 4-in. pin.

The timber towers for the cableway were of different heights, owing to the profile of the

ground. The west tower was about 100 ft. high and had its base on nearly level ground, but at the site of the east tower the bank had a considerable slope both longitudinally and transversely, and a pit, having an average depth of about 12 ft., was dug in order to level the base of this tower, which was then about 75 ft. high from its base.

Each tower consisted of two transverse bents 20 ft. wide on centers and about 15 ft. apart longitudinally at the foot, and 2 ft. apart at the top. Each bent was made with two  $8\times 8$ -in. posts connected by horizontal struts averaging about 12 ft. apart with X-bracing in double panels. The  $12\times 12$ -in. sills were seated on four  $12\times 12$ -in. sleepers 23 ft. long. The caps of the towers overhung the main posts and were guyed by lateral and back guys of wire rope attached to eye-bolts passing through them near the ends. These caps carried a pair of rails about 18 in. apart, on which the cable saddle was seated. This saddle consisted of a solid timber block with a wide steel base-plate projecting on both sides and on one end to furnish connections for the traversing rope and for a backstay rope. The sides of the block were protected by channels bolted to them, and a longitudinal groove was cut in each block to receive the cable, which was locked in position by a cap piece fastened over it by V-bolts. The saddle was moved along the caps, when it became necessary to shift the cable, by wire ropes, attached to each side and led over sheaves at the ends, and thence down to hand tackles.

Close to the west anchorage an adjustment for the cable was provided by interposing a sheave frame made of a pair of transverse steel beams, one of which was connected to the cable and the other to the top of the vertical anchor bar, each beam consisting of a pair of 15-in. channels, back to back, with a space sufficient for four sheaves between each pair. These sheaves were rove with two  $\frac{5}{8}$ -in. steel wire ropes, so as to correspond to a ten-part tackle. One end of each rope was fastened to the beam at the anchor end, and the other end, after engaging four sheaves, was clamped to a short rope connected to the opposite beam. Beyond the clamp the main rope passed down to a hand tackle by which it could be adjusted.

In operation, if it was necessary to shorten or lengthen the main cable while in service, a strain was put on the two tackles connected to

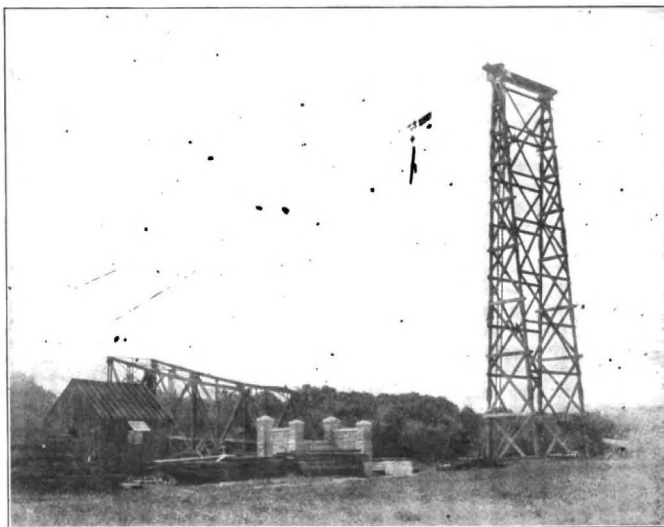

Cableway Tower with Traveling Saddle.

ground. The west tower was about 100 ft. high and had its base on nearly level ground, but at the site of the east tower the bank had a considerable slope both longitudinally and transversely, and a pit, having an average depth of about 12 ft., was dug in order to level the base of this tower, which was then about 75 ft. high from its base.

Each tower consisted of two transverse bents 20 ft. wide on centers and about 15 ft. apart longitudinally at the foot, and 2 ft. apart at the top. Each bent was made with two  $8\times 8$ -in. posts connected by horizontal struts averaging about 12 ft. apart with X-bracing in double panels. The  $12\times 12$ -in. sills were seated on four  $12\times 12$ -in. sleepers 23 ft. long. The caps of the towers overhung the main posts and were guyed by lateral and back guys of wire rope attached to eye-bolts passing through them near the ends. These caps carried a pair of rails about 18 in. apart, on which the cable saddle was seated. This saddle consisted of a solid timber block with a wide steel base-plate projecting on both sides and on one end to furnish connections for the traversing rope and for a backstay rope. The sides of the block were pro-

ected by channels bolted to them, and a longitudinal groove was cut in each block to receive the cable, which was locked in position by a cap piece fastened over it by V-bolts. The saddle was moved along the caps, when it became necessary to shift the cable, by wire ropes, attached to each side and led over sheaves at the ends, and thence down to hand tackles.

Mr. Edward S. Shaw, of Boston, was the designer and supervising engineer of this bridge. The New England Structural Co., of Boston and Everett, Mass., was the contractor for the superstructure; Mr. W. B. Douglass was chief engineer, and Mr. E. N. Pike chief draughtsman of this company. Messrs. Ellis & Buswell, of Woburn, Mass., were the contractors for the substructure.

AIR LEAKAGE THROUGH BOILER SETTINGS of brick can be lessened by giving the walls two coats of Portland cement wash and then one coat of cold-water paint to brighten them up, according to Mr. Wm. C. McCracken, in a recent paper on boilers and furnaces before the Ohio Society of Mechanical, Electrical and Steam Engineers.



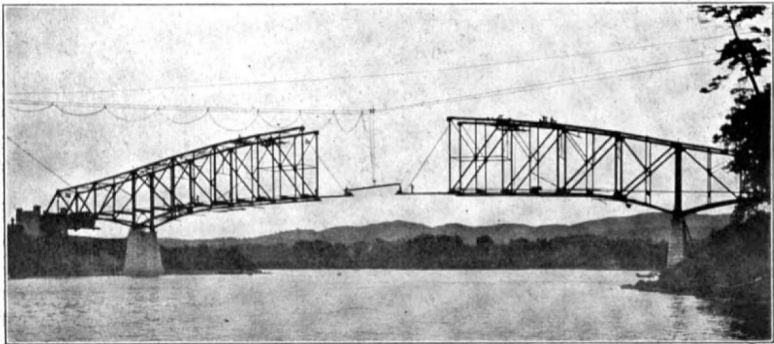

**Cantilever Erection with Cableway, Schell Memorial Bridge.**